

Food Safety

Your Self-Training Manual



Oregon Department of Human Services
Foodborne Illness Prevention Program

Why Read This Book?	1
Food Handler Card.....	1
Training Required.....	1
Reciprocity and Equivalency	1
How to Use This Book.....	2
A "Person in Charge" is Required	2
Keep This Book to Use as a Reference	3
Learning Objectives.....	4
Employee Illness	4
Handwashing.....	5
Your Role in Helping Prevent Foodborne Illness.....	7
The Role of Management	8
Foodborne Illness	8
Temperature Control	9
Final Cooking Temperature.....	10
Contamination and Cross Contamination.....	10
Your Own Health Comes First	11
Work Only When You Are Well	11
Review	12
Prevent the Spread of Disease.....	13
Handwashing is Very Important.....	13
Double Handwash.....	13
Germs are Everywhere	14
Review	15
Employee Practices.....	16
How You Look and How You Act	16
Fingernails	16
Gloves can spread germs.....	16
Beverages	16
What Makes People Sick From Food?	17
Foodborne Illness	17
Potentially Hazardous Foods.....	17
Bacteria.....	17

Other Germs	18
Chemicals	18
Physical Contamination	18
Food Temperatures	19
Temperature Control	19
The "Danger Zone"	19
When to Discard Food.....	19
Cooking Food	19
When is Cooked Food Safe?	19
Cold Holding	20
Hot Holding	20
Review	21
Safe Storage Practices.....	22
A Clean Workplace is Safer.....	24
Follow These Important Rules.....	24
Utensils, Surfaces and Equipment.....	25
Review.....	26
Glossary.....	27
Practice Test	29
Reference Section.....	32
Employee Illness	33
Handwashing.....	34
Cooking Temperatures.....	35
How To Use a Food Thermometer	37
Calibrating A Food Thermometer.....	39
Cooling Hot Foods	40
Date Marking	43
Pests.....	43

Why Read This Book?

Food Handler Card

All food handlers employed in food service must obtain a food handler card within 30 days from the date of hire. As a food handler, you are required to keep your food handler card current by renewing it every three years.

Training Required

The goal of this program is to provide you with a basic understanding of food safety. This will assist your manager, who is responsible for ensuring that you prepare and serve food safely. **A food handler card confirms that you have met the learning objectives in this book.**

Reciprocity and Equivalency

Any person who has a current certificate from a Department-approved food manager certification program need not obtain a food handler card.

To be accepted in place of a food handler card, a food manager certificate must be current and renewed upon expiration.

Photocopies of the food handler cards and food manager training certificates should be kept at the facility to show the health inspector upon request.

**How to use
this book**

This book is intended to help you learn what you need to know to obtain a food handler card. You will need a score of 75% to pass. You will be tested on all of the learning objectives that are listed on pages (4-9). Throughout this book you will find study questions that will help you get ready to take the test for the food handler card. At the end of the book is a practice test for you to take and see how you do.

The words that are *italicized* and **bold** are explained in the glossary located in the back of this book.

**A "Person
in Charge"
is Required**

Someone at your restaurant must be in charge during all hours of operation. This person in charge (PIC) is responsible for knowing the food sanitation rules and the procedures within your establishment. This person is responsible for providing you with information you need to perform your job.

The PIC is usually a manager or supervisor, but can be anyone who can demonstrate the knowledge listed above, and is given the authority to oversee other employees.

Keep This Book to Use as a Reference

This book is yours and should be kept at hand in case you have any questions. If something comes up that you cannot answer with this book, ask the **“person in charge”** or call your local county health department for help.

Phone numbers of the **local health department in your county:**

Baker	541-523-8211	Lake	541-947-5646
Benton	541-766-6841	Lane	541-682-4051
Clackamas	503-650-3569	Lincoln	541-265-4127
Clatsop	503-325-8500	Linn	541-967-3821
Columbia	503-366-3828	Malheur	541-473-5186
Coos	541-756-2020	Marion	503-588-5346
Crook	541-447-8155	Morrow	541-278-6394
Curry	541-247-3300	Multnomah	503-988-5257
Deschutes	541-388-6575	Polk	503-623-9237
Douglas	541-464-3820	Sherman	541-506-2600
Gilliam	541-506-2600	Tillamook	503-842-3918
Grant	541-575-0429	Umatilla	541-278-6394
Harney	541-573-2271	Union	541-962-8800
Hood River	541-386-1115	Wasco	541-506-2600
Jackson	541-774-8206	Wallowa	541-426-4848
Jefferson	541-475-4456	Washington	503-846-8722
Josephine	541-474-5325	Wheeler	541-475-4456
Klamath	541-883-1122	Yamhill	503-434-7525

See Inside Back Cover for Web Addresses

Food Handler Training

Learning Objectives

Food workers are expected to know this information to obtain their food handler card.

The concept of foodborne illness will be introduced. The training will address personal hygiene, contamination, and temperature control to reinforce the food handler's behaviors, which can prevent foodborne illness.

Employee Illness

1. The food handler will know to call the person in charge at the food service facility when ill with diarrhea, vomiting, jaundice, or fever with sore throat.
2. The food handler will know not to work in the food service facility while ill with these symptoms.
3. The food handler will know not to handle food with an infected boil, cut, burn, or sore on the hand or wrist. Food may be handled if the injury is covered with a clean bandage and a latex-free glove.

Handwashing

Workers will understand elements of good handwashing.

1. The food handler will be able to identify the correct technique for handwashing:
 - Use running warm water and soap
 - Scrub hands and rinse thoroughly (approximately 20 seconds)
 - Dry hands with single-use towel, or air dryer

2. The food handler will be able to identify situations when food handlers must wash their hands:
 - After handling raw food and raw animal products
 - After handling dirty dishes
 - After handling garbage
 - After cleaning or using chemicals
 - Before putting on food service gloves, and after removing gloves

3. The food handler will know that a double handwash means to lather hands with soap and warm water for approximately 20 seconds, rinse, and repeat a second time. Dry hands with paper towels or air dryer.

4. The food handler will be able to identify situations when food handlers must wash their hands twice (double handwash):
 - After using the toilet and again when entering work area (double handwash)
 - After blowing nose, sneezing, coughing, or touching eyes, nose or mouth (double handwash)
 - Before starting work (double handwash)
 - Anytime hands come into contact with body fluids (double handwash)
 - After smoking, or using tobacco products (double handwash)
 - After eating or drinking (double handwash)
5. The food handler will know that food service gloves are capable of spreading germs and are not a substitute for proper handwashing.
6. The food handler will know that smoking, eating, and chewing tobacco are prohibited in food preparation areas, including food and utensil storage areas.

Your Role in Helping Prevent Foodborne Illness

1. The food handler will be able to describe five major mistakes that often cause foodborne illness:
 - Inadequate handwashing
 - Employees working while they are ill
 - Cross contamination
 - Inadequate cooking temperatures
 - Inadequate temperature control (allowing foods to be in the danger zone)

2. The food handler will be able to describe the activities performed by food handlers that prevent foodborne illness from happening. Activities preventing foodborne illness include:
 - Proper handwashing every time hands may have become contaminated
 - Food handlers working only when healthy
 - Storing and handling of foods in a manner to prevent contamination
 - Cooking each animal product to its required internal temperature
 - Maintaining hot and cold temperatures (keeping foods out of the danger zone)

The Role of Management in Helping Prevent Foodborne Illness

1. The food handler will know that the manager sets the tone of what food safety activities occur or don't occur within the facility.
2. The food handler will know that the food service management is responsible for training and ensuring that food handlers practice activities that prevent foodborne illness.

Foodborne Illness

1. The food handler will be able to describe foodborne illness as an illness resulting from eating contaminated food.
2. The food handler will know that food contaminated with organisms (germs) does not always look, smell or taste different from non-contaminated food.
3. The food handler will know that symptoms vary and may include diarrhea, vomiting, fever, cramping and nausea.
4. The food handler will know that depending on the cause, symptoms may develop in a few minutes to several days. Some symptoms may last several days and can result in death.
5. The food handler will know that foodborne illness is caused by organisms (germs), chemicals, or toxins.

Temperature Control

Workers will understand why hot and cold holding temperatures are important factors in preventing illness.

1. The food handler will be able to identify potentially hazardous foods as food that will support bacterial growth when held at temperatures in the danger zone.
2. The food handler will be able to identify the danger zone as any temperature between 41 degrees F and 140 degrees F.
3. The food handler will be able to identify that food being cooled or heated must move through the danger zone as rapidly as possible.
4. The food handler will be able to identify 140 degrees F or hotter as the proper temperature for hot holding potentially hazardous food.
5. The food handler will be able to identify 41 degrees F or colder as the proper temperature for cold holding potentially hazardous food.
6. The food handler will know that you cannot make food safe to eat when food has been in the danger zone for four hours or more.

Final Cooking Temperature

Workers will understand why cooking foods to proper temperatures are important for preventing illness.

The food handler will be able to identify that cooking foods to the recommended temperature will kill disease-causing germs.

Contamination and Cross Contamination

Workers will understand why cross contamination is dangerous and know ways to prevent it.

1. The food handler will be able to define and identify physical contamination as foreign objects accidentally introduced into food. Food items may arrive already contaminated with dirt and pebbles.
2. The food handler will be able to define and identify cross contamination as happening when microorganisms are transferred from one food or surface to another food.
3. The food handler will be able to identify methods to prevent cross contamination such as washing, rinsing, and sanitizing utensils, work surfaces and equipment between uses.
4. The food handler will be able to identify storage conditions that will minimize the potential for cross contamination:
 - Store raw meats below and completely separate from ready-to-eat food in refrigeration units
 - Store chemicals, cleansers and pesticides completely separate from food, utensils, and single service items
 - Properly label all chemicals, cleansers and pesticides

Your Own Health Comes First

Work Only When You Are Well

If you feel sick you should not go to work. The germs you bring to work can spread when you touch food, dishes, counters, utensils, and other people.

- Do not work if you have a fever and sore throat
- Do not work if you have loose bowels (diarrhea)
- Do not work if you are throwing up (vomiting)
- Do not work if you have yellowing of the skin or dark tea colored urine (jaundice)

Tell your manager if you have any of these symptoms. If the manager has questions, he or she can call the County Health Department (see page 3).

Do not handle food with an **infected** boil, burn, cut or sore on your hand. Food may be handled if you cover the injury with a clean bandage, and wear a latex-free glove.

Prevent the Spread of Disease

Hand Washing is Very Important

Wash your hands often when working with food and drinks - this gets rid of germs that can make people sick. Wash your hands for approximately **20 seconds** with warm running water and soap, and then dry them with clean paper towels, or an air dryer.

Remember to always wash your hands:

- **Before** you touch anything used to prepare food
- **Before** you touch food that will not be cooked
- **Before** you put on latex-free gloves and after you remove them
- **After** you work with **raw** meat, fish and poultry
- **After** you handle trash and take out garbage
- **After** you handle dirty dishes
- **After** cleaning or using chemicals

Double Handwash is Required

Double handwash is required before starting work, and when your hands come into contact with body fluids. Lather hands with soap and warm water for approximately 20 seconds, rinse, and repeat a second time. Dry hands with paper towel or air dryer.

Double Handwash

It is necessary to wash your hands a second time:

- **After you go to the restroom** (use the toilet) and wash hands again when you return to the kitchen
- **After** you eat or drink an open beverage
- **After** you blow your nose, cough or sneeze, because your hands have touched your nose or mouth
- **After** smoking or using tobacco products

Germs are Everywhere

Germs such as **bacteria** and **viruses** are everywhere. Think of your hands and fingernails as easily "contaminated." Just because they look clean does not mean they are clean. Germs are too tiny to see with your eyes. If you do not wash your hands in the right way and keep your fingernails trimmed short, your hands can put germs in food that will be eaten by your customers. They may get sick from these germs. This is called "**foodborne illness**" or "food poisoning."

Review

Write your answers to the study questions in the space provided.

1. What is it called when someone gets sick from eating food contaminated with germs or toxins?
2. How long must you wash your hands?
3. When must you wash your hands?
4. What is a double handwash?
5. When must you do a double handwash?

Employee Practices

Take Care of How You Look and How You Act

Do not smoke or chew tobacco while you are working or when you are near food or dishwashing areas. Smoke only while you are on a break. After you smoke, wash your hands **twice** before you return to work (double handwash).

Fingernails

Be sure to scrub underneath your fingernails. It is much easier to keep fingernails clean when they are kept short.

Gloves can spread germs

Single-use food service gloves can also spread germs. Always wash and dry your hands before putting on gloves. Wash again when gloves are removed. Change gloves between tasks. When you wear gloves be aware that gloves can spread germs onto food that will not be cooked. Even when you wear gloves, it is best to keep fingernails short.

Beverages

When you are thirsty while working, you may drink from a closed beverage cup with lid and straw or cup with lid and handle. This is allowed only if the food worker is careful to prevent contamination of hands, equipment, any service items, and exposed food.

What Makes People Sick From Food?

Foodborne Illness	People can get sick when the food they eat has germs. Germs cause <i>foodborne illness</i> or food poisoning.
Potentially Hazardous Foods	Germs grow easily in foods like meat, fish, poultry, milk, re-fried beans, cooked rice, baked potatoes and cooked vegetables. These are called <i>potentially hazardous foods</i> . These are all foods that are moist and they have nutrients that the germs need to grow. Germs grow well on these foods at warm temperatures between 41°F and 140°F.
Bacteria	Different kinds of germs can make people sick. <i>Bacteria</i> are one kind of germ. They grow fast and they may cause <i>foodborne illness</i> . Some <i>bacteria</i> make toxins that act like a poison. Cooking does not destroy most toxins. Almost always, the food looks and smells good, but it may have enough <i>bacteria</i> or toxin to make someone sick. Toxins can occur in many foods that have not been kept cold enough or hot enough.

Other Germs	A <i>virus</i> is another kind of germ that causes illness when it gets into the food.
Viruses	You can have a virus and not know it. Even before you start feeling sick, you may be passing viruses into the food by not washing your hands after coughing, sneezing or using the toilet. This is one reason why the law requires all food workers to wash their hands twice (double handwash) using lots of soap and warm water.
Parasites	Tiny worms that live in fish and meat are called parasites . Cooking fish and meat to the right temperature will kill parasites .
Chemicals	People can also get sick when chemicals get into the food. Be sure to keep chemicals away from food.
Physical Contamination	Physical contamination is when foreign objects are accidentally introduced into food. Food items may arrive already contaminated with dirt, and pebbles. Physical contamination such as broken glass can also happen at the facility.
Contaminated Food	The food is contaminated. Now what? Discard contaminated food, and notify your manager right away!

Food Temperatures

Temperature Control	This section is about killing germs with cooking and stopping their growth by keeping the food hot or cold. This is called temperature control , and your restaurant needs at least one accurate metal-stem probe (food) thermometer to check food temperatures.
The "Danger Zone"	Germs like <i>bacteria</i> need time, food and moisture to grow. The temperature between 41°F(5°C) and 140°F(60°C) is called the "Danger Zone!" When food sits in the "Danger Zone" , <i>bacteria</i> can grow fast and make toxins that can make you and others sick.
When to Discard Food	Foods left in the Danger Zone for more than four hours must be discarded. Reheating the food may kill the bacteria but the toxins (produced by bacteria) will remain in the product and cause illness.
Cooking Food	Cooking raw food to the proper temperature will kill germs that cause people to become sick.
When is Cooked Food Safe?	Different foods have to reach different temperatures to be done or safe. Ask your manager to show you a temperature chart for cooking meats (see reference in back of this manual). Be sure to cook the food to the temperature that is shown on the chart.

Remember You can choose several ways to cook food. No matter how you cook the food, it must reach the correct cooking temperature. Using a metal-stem probe thermometer is the only way to know the correct temperature of food. You must place the thermometer in the thickest part of the meat or in the center to get a true reading.

Cold Holding Always keep cold food at 41°F(5°C) or colder. Fish, shellfish, poultry, milk and red meat will stay fresh longer if you hold them cold at 41°F(5°C) or colder.

Hot Holding After the food is cooked and ready to serve, you will need to keep it warm enough to stop any germs from growing. You must turn on steam tables, soup warmers and heated surfaces before you need them so that they will be hot enough when you put the cooked food into them.

Keep hot food at 140°F(60°C) or hotter.

Keep it Hot Stir food to help keep the food on top hot. A cover on the pan helps to keep the heat inside.

Keep it Cold Food being held cold on the top section of a refrigerated preparation unit also benefits from being covered.

Review

1. What is the temperature for holding food hot?
2. What is the temperature for holding food cold?
3. What are some ways to help keep food hot?
4. Why use a metal-stem probe thermometer?

Safe Storage Practices

You want all the food you use to be healthy and safe. This section talks about how to safely store and handle food.

Cross Contamination

Cross contamination happens when germs from raw or unclean food get into foods that are ready to serve or that will not be cooked again before you serve them.

Keep Foods Safe From Contamination

As a food handler you must prevent **cross contamination**. Here are some important ways that you can prevent **cross contamination**.

Store raw meat, fish and poultry on the lower shelves of the refrigerator.

Don't let raw meats; beef, pork, lamb, fish or poultry drip onto foods that will not be cooked before serving.

Keep different types of raw meat separate from each other.

Store unwashed food or raw food away from ready-to-eat food.

Wash your hands between handling raw meat and foods that will not be cooked before eating.

**Keep Foods
Safe from
Contamination**

Never store foods that will not be cooked before serving in the same container as raw meat, fish or poultry.

Wash your hands before handling food.

Wash, rinse and **sanitize** the cutting surface and all the utensils and knives **every time** you finish with a job or between preparing different foods.

Use clean utensils instead of hands for dispensing food.

Store foods away from cleaners and poisons.

A Clean Workplace is Safer

It takes more than soap and water to keep a food business clean and safe. You will likely be using detergents and sanitizers.

Follow These Important Rules

- Know what the directions say for using chemicals. Read the labels and talk to your manager about when to use them and how much to use. **Be sure you understand and follow the directions!**
- Keep chemicals away from food and clean utensils. If chemicals must be stored in the same room, be sure they are stored in their own area. The area should be below food and utensils, so there is no chance of chemicals splashing onto the food and utensils.
- Can you read what the labels say? Are they easy to see? If they are not, tell your manager.
- Keep all chemicals in the bottles or boxes they come in. If you put them in a different container, label them clearly.

**Utensils,
Surfaces and
Equipment**

Another way to prevent cross contamination is to be sure that utensils, work surfaces and equipment are washed, rinsed, and sanitized between uses.

- **Wash** them in hot soapy water
- **Rinse** them in clean hot water
- **Sanitize** them with freshly prepared sanitizer (1 to 2 teaspoons of bleach per 1 gallon of water)

Directions

Follow the cleaning directions for each piece of equipment.

Remember

The correct steps for cleaning utensils, food contact surfaces and equipment are:

- 1. Wash**
- 2. Rinse**
- 3. Sanitize**

Glossary

Bacteria - Bacteria are germs with only one cell that can multiply into large numbers when food is in the danger zone for more than 4 hours.

Chemicals - In this book, chemicals are referred to as ingredients in cleaning, sanitizing, or pesticide products that make people sick if eaten.

Cold Holding - Cold holding is when you keep food cold by using refrigeration or ice.

Cross Contamination - When germs from one food item are passed to another food item, usually raw food to ready-to-eat food.

Double Handwash - Lather hands with soap and warm water for approximately 20 seconds, rinse, and repeat a second time. Dry hands with paper towel, air dryer or roll of linen towels.

Danger Zone - The Danger Zone is when the temperature of food is between 41°F(5 ° C) and 140°F(60 ° C). This is called the danger zone because bacteria will grow quickly between these temperatures.

Foodborne Illness- Sickness caused from germs or toxins in food. This is also called food poisoning.

Food Thermometer - A metal-stem probe thermometer used to take temperatures of food.

Hot holding - Holding food hot after it has been properly cooked or reheated. Food must maintain a temperature of 140°F(60 ° C) or hotter.

Infected - A cut or burn that is swollen, red, or has pus.

Reheating - The process of making a cold food hot. Food must be heated food from 41°F(5 ° C) to 165°F(74 ° C) within two hours.

Parasites - These are tiny worms that live in fish, meat and humans.

Potentially Hazardous Foods - Moist, nutrient-rich foods that supports the growth of bacteria when the temperature is between 41°F(5 ° C) and 140°F(60 ° C).

Sanitize - The final step to removing bacteria from food contact surfaces that have just been cleaned. Many places use a solution made up of one teaspoon of bleach to one gallon of water to sanitize equipment and utensils.

Virus - Viruses are germs that can only reproduce inside of a living cell. It takes a small number of viruses to make someone sick. Many viruses get into the food from the lack of handwashing especially after using the toilet and then touching food.

Practice Test

Choose the best answer for each question.

1. Which of the following statements is true? After touching raw ground beef, it is important to:
 - A. Wipe your hands on a sanitizer wipe cloth
 - B. Use a hand sanitizer before touching anything else
 - C. Wash your hands with soap and water
 - D. Dip your hands in a bucket of sanitizer

2. When must you double handwash?
 - A. After sneezing or coughing
 - B. After touching raw meat
 - C. After eating or drinking
 - D. A and C

3. What is proper handwashing?
 - A. Using soap, running water and scrubbing 20 seconds
 - B. Using sanitizer, running water and scrubbing for 20 second
 - C. Using soap, running water and scrubbing for 10 seconds
 - D. Using sanitizer, running water and scrubbing for 10 seconds

4. It is okay to wear disposable gloves if:
 - A. You wear a pair of gloves to handle money and food
 - B. You wash your hands first and discard gloves between activities
 - C. You discard the gloves every few hours or at least once a day
 - D. You blow into the gloves first to make them easier to put on

5. When you have a sore throat or diarrhea, you should:
 - A. Go to work and tell your coworkers to be careful around you
 - B. Call your manager and report that you are sick
 - C. Take medicine to stop the symptoms and go to work
 - D. Not tell anyone and continue working

6. Preparing food several hours in advance can make food unsafe because:
 - A. Bacteria can grow if the food temperatures fall into the danger zone
 - B. Foods can lose their flavor, color and general quality
 - C. Foods can lose their nutritional value
 - D. Refrigerators can only hold so much food

7. The most important reason to wash, rinse and sanitize cutting boards is to:
- A. Eliminate odors and tastes from getting into other foods
 - B. Make the cutting board look better and last longer
 - C. Prevent contamination from one food to another
 - D. Prevent flavors and garlic or onion juices from getting onto other foods
8. What is the minimum temperature that hot food must be kept at on the steam table to keep food safe?
- A. Hot - 140°F
 - B. Hot - 130°F
 - C. Hot - 120°F
 - D. Hot - 165°F
9. What is the maximum temperature that cold food must be kept at on the salad bar to keep food safe?
- A. Cold - 51°F
 - B. Cold - 65°F
 - C. Cold - 41°F
 - D. Cold - 55°F

Answers:

- | | | |
|------|------|------|
| 1. C | 4. B | 7. C |
| 2. D | 5. B | 8. A |
| 3. A | 6. A | 9. C |

Reference Section

Food safety questions may come up that were not covered in the food handler training section of this manual. This reference section provides some additional food safety information.

The Oregon Food Sanitation Rules - For information on all food service regulatory requirements see the Oregon Food Sanitation Rules. Every person in charge (PIC) needs to have easy access to these rules. The rules are available for downloading into your computer in an Adobe portable document format (pdf) at <http://oregon.gov/DHS/ph/foodsafety/index.shtml>

Person In Charge (PIC) - The Oregon Food Sanitation Rules require that the licensee designate a person in charge (PIC) during all hours of the operation. The PIC must know foodborne illness prevention and the requirements of the Oregon Food Sanitation Rules. Every PIC must also know the policies and procedures within the food establishment. If a PIC is not able to demonstrate knowledge, or is not onsite, the facility will receive a critical violation during an inspection. Please refer to chapter two of the Oregon Food Sanitation Rules to learn about the requirements of the PIC.

Food Service Inspection Process - All establishments must follow standard food-safety practices critical to the safety and quality of the food served. During health department inspections, the inspector compares the Oregon Food Sanitation Rules to the procedures at your establishment. The PIC can solicit help from the health department on how to prepare for an official regulatory inspection. The PIC can learn to identify every food safety problem, and how to correct it.

Employee Illness

Employee Illness - Infected food workers can spread a wide range of illnesses to consumers and co-workers through food and utensils.

Employees are required to report to the PIC when ill with any of the diseases listed below, or they live in the same household as a person with one of these diseases. An employee suffering from diarrhea, fever, vomiting, jaundice, and sore throat with fever must also report this information to the PIC. **The PIC is required to inform employees of this responsibility.**

The Most Common Illnesses Transmitted from Employees to Others through Food and Utensils

Foodborne Illnesses*	Common Symptoms				
	D	F	V	J	S
1. Hepatitis A virus		F		J	
2. Salmonella Typhi		F			
3. Shigella	D	F	V		
4. E. coli O157:H7	D				
5. Norwalk or Noro viruses	D	F	V		
6. Staphylococcus aureus	D		V		
7. Streptococcus pyogenes		F			S

KEY: D = Diarrhea V = Vomiting
 J = Jaundice F = Fever S = Sore throat with Fever

Note: *The PIC is required to notify the county health department when an employee has Hepatitis A, Salmonella Typhi, Shigella or E. coli O157:H7.

Handwashing

Keeping Hands Clean - Food employees with dirty hands and/or dirty fingernails may contaminate the food being prepared. Any activity that may have contaminated the hands must be followed by thorough handwashing as described in this manual (see pages 5 & 13).

Cleaning Procedure - Many employees fail to wash their hands as often as necessary and even those who do may use a poor technique. It takes vigorous rubbing with soap and running water for about 20 seconds to loosen soil and illness-causing organisms (germs).

Many diseases transferred through food may be harbored in the employee's intestinal tract and shed in the feces. Proper handwashing after a bowel movement establishes a barrier against the transfer of organisms (germs) present in the feces.

Hand Sanitizers - Sanitizer dips or hand sanitizers are **not** approved handwash techniques and are not acceptable substitutes to handwashing.

Fingernails - The requirement for fingernails to be trimmed, filed, and maintained is designed to address the ability to clean beneath the fingernails and the possibility that fingernails or pieces of the fingernails may end up in the food due to breakage. Failure to remove fecal material from beneath the fingernails after a bowel movement can be a major source of illness causing organisms. Ragged fingernails may harbor harmful organisms.

Jewelry - Items of jewelry such as rings, bracelets, and watches may act as a hiding place for foodborne illness causing organisms (germs). An additional hazard associated with jewelry is the possibility that pieces of the item or the whole item itself may fall into the food being prepared. Hard foreign objects in food may cause medical problems for consumers, such as chipped and or broken teeth and internal cuts and lesions.

Cooking Temperatures

Cooking Temperatures - Different raw animal foods have to reach different temperatures to be done or safe. Use a metal-stem probe food thermometer to check temperatures while cooking to make sure that it gets done all the way inside.

Why Use a Food Thermometer? Using a metal-stem probe food thermometer when cooking meat, poultry, and even egg dishes is the only reliable way to know that the temperature of food is hot enough to kill harmful bacteria. Using a thermometer also helps you to avoid overcooking, giving you a safe and flavorful meal.

Cooking Requirements for Specific Foods

The next page shows the temperature that specific foods must reach to be safe.

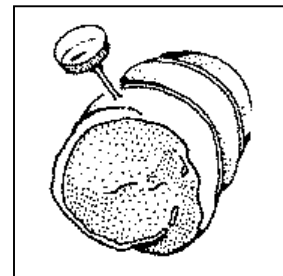



Cooking Requirements for Specific Foods		
Animal Product	Minimum Temperature	What to Know?
Poultry, Ground Poultry	165°F (74°C) for 15 seconds	Stuffing should be cooked outside of poultry.
Stuffing, Stuffed Meats, Casseroles and dishes combining raw and cooked food	165°F (74°C) for 15 seconds	Stuffing acts as an insulator, preventing heat from reaching the meat's center. Stuffing should be cooked separately.
Ground or Flaked Meats hamburger, ground pork, flaked fish, ground game animals, sausage, injected and pinned meats	155°F (68°C) for 15 seconds	Grinding meat mixes the organisms from the surface into the meat. Alternative minimum internal temperatures for ground meats: 150°F (66°C) for 1 minute 145°F (63°C) for 3 minutes
Pork, Beef Steaks, Veal Lamb, Commercially Raised Game Animals	145°F (63°C) for 15 seconds	This temperature is high enough to destroy Trichinella larvae that may have infested pork.
Beef or Pork Roasts	145°F(63°C) 3 minutes	Alternative minimum internal cooking temperatures for beef and pork roasts: 130°F (54°C) for 121 minutes 134°F (57°C) for 47 minutes 138°F (59°C) for 19 minutes 140°F (60°C) for 12 minutes 142°F (61°C) for 8 minutes 144°F (62°C) for 5 minutes
Fish, Foods containing fish, and Seafood	145°F(63°C) 15 seconds	Stuffed fish should be cooked to 165°F (74°C) for 15 seconds. Fish that has been ground, chopped, or minced should be cooked to 155°F (68°C) for 15 seconds
Shell Eggs for immediate service	145°F(63°C) 15 seconds	Only take out as many eggs as you need. Never stack egg flats near the grill or stove. Eggs cooked for later service must be cooked to 155°F for 15 seconds and held at 140°F.
Foods cooked in Microwave Meat, Poultry, Fish, Eggs	165°F (74°C) let it stand for 2 minutes after cooking	Cover food, rotate or stir it halfway through the cooking process.

"Is It Done Yet?" How To Use a Food Thermometer

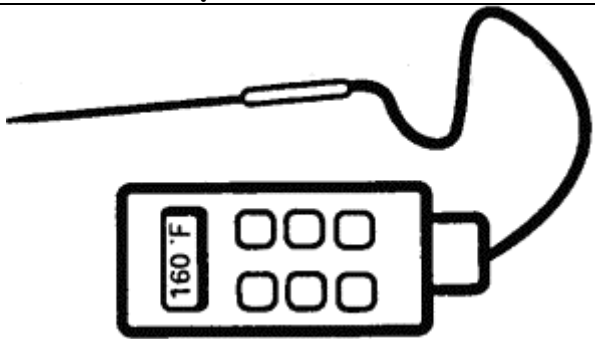

1. A thermometer that works best shows a range of 0°F(-18°C) to 220°F(104°C).
2. Check the internal temperature of the food toward the end of the cooking time.
3. Place the thermometer in the thickest part of the meat or in the center of the food to get a true reading. (Do not touch the bone with the stem of the thermometer to prevent a false reading).
4. When taking temperatures of a large amount of food like a big piece of meat, be sure to take the temperature in two or more locations.
5. Compare your thermometer reading to the Required Cooking Temperatures to determine if your food has reached a safe temperature.
6. Wash and sanitize the thermometer each time you check the temperature of a food.

Refrigerator Thermometer - Every refrigerator is required to have a thermometer. This thermometer must be located where it is easy to see when you open the refrigerator door. Every **refrigerator** should be operating at 41°F or less as indicated by the thermometer. If the thermometer reads above 41°F, then use a metal-stem probe **food thermometer** to check the temperature of food inside of the refrigerator with a food thermometer (see above).

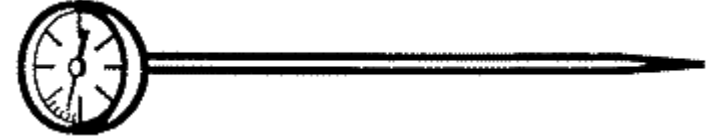
Types of Food Thermometers	Speed	Placement
<p data-bbox="233 289 483 331">Thermocouple</p>  <p data-bbox="435 672 941 709">Most models can be calibrated</p>	<p data-bbox="964 289 1107 382">2-5 seconds</p>	<p data-bbox="1169 289 1393 432">$\frac{1}{4}$" or deeper in the food as needed</p>
<p data-bbox="233 730 438 772">Thermistor</p>  <p data-bbox="422 1117 941 1155">Some models can be calibrated</p>	<p data-bbox="964 730 1107 823">10 seconds</p>	<p data-bbox="1169 730 1373 873">At least $\frac{1}{2}$" deep in the food</p>
<p data-bbox="233 1163 630 1205">Instant-Read Bimetal</p>  <p data-bbox="412 1470 941 1507">Most models can be calibrated</p>	<p data-bbox="964 1163 1107 1255">15-20 seconds</p>	<p data-bbox="1169 1163 1390 1205">2- 2 $\frac{1}{2}$" deep</p>

Refer to manufacturer instructions to find out if your thermometer can be calibrated. Check the web or your food supplier to obtain the best thermometer for your establishment.

Calibrating A Food Thermometer

When you use a food thermometer you need to make sure the temperature it gives you is accurate. An easy way to do this is to use ice and water.

Pack a large cup to the top with crushed ice and water.

Put the thermometer at least 2 inches into the ice slurry. After 30 seconds, read the dial. It should read 32°F (0°C).

If it does not read 32°F(0°C) after 30 seconds, you need to:

1. Leave it in the ice slurry. Add ice as it melts.
2. Use pliers or a wrench and turn the nut on the back of the thermometer until the needle reads 32°F(0°C).
3. Wait 30 seconds. Keep repeating these steps until the thermometer reads 32°F(0°C).

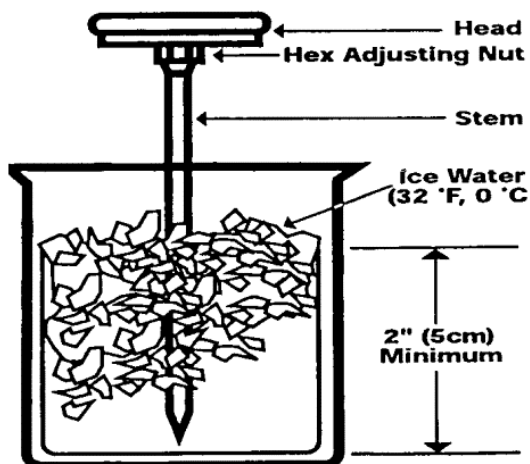

Daily

Calibrate your **food thermometer** every day and whenever it is bumped or dropped.

This way you will know that it is telling you the correct temperature.

Cooling Hot Foods

With cooling of foods it is important to move the food temperature through the "Danger Zone" as quickly as possible to keep food safe.

Fresh is Best - You always take a chance that bacteria can grow and produce toxins when you cool food. **It is safest to make food fresh each day, just before you serve it.**

Speed is Important with Cooling - If you must make food in advance or save leftover food, cool it as **fast** as you can to prevent bacteria growth and toxin production.

Reheating will not destroy toxins.



Cooling Solid Foods - When cooling solid cooked foods such as roast, turkey, and solid cuts of meat, be sure to:

1. Cut large roasts and turkeys into smaller portions. This will help them to cool faster.
2. Put all meats and other hot food in the refrigerator.

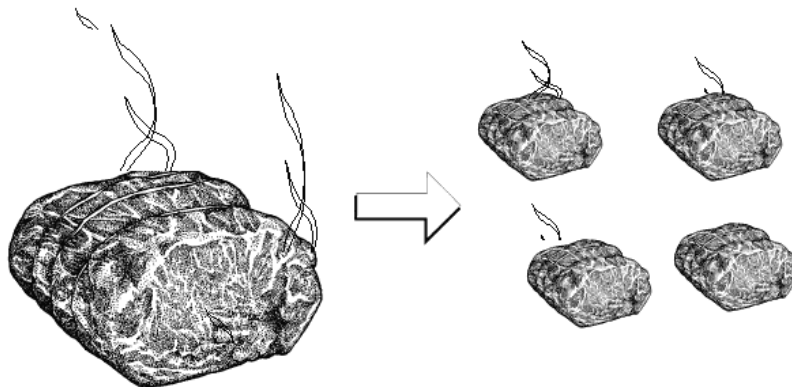

Cooling Soft/Thick Foods - Examples of soft/thick foods are refried beans, rice, potatoes, stews, chili, thick soup or thick sauces.

You can cool soft/thick foods by pouring food into a shallow metal pan. Use a sheet pan for very thick foods like refried beans.

Cooling thick food is not easy. Whenever possible use a flat pan and spread the food out as shallow as you can to speed up the cooling.

When cooling food in shallow metal pans, be sure to:

1. Pour hot food into shallow metal pans. The shallower the pan the faster the food will cool.
2. Stirring food speeds up cooling time.
3. Once food cools to 41°F(5°C), you can place food in a larger container and cover it.

Air Movement - Air in the refrigerator must be able to move around the food. The pans and dishes need to have space between them; do not crowd them. Do not stack pans on each other. Do not cover the food while it is cooling. A cover may be put on after the food has fully cooled.

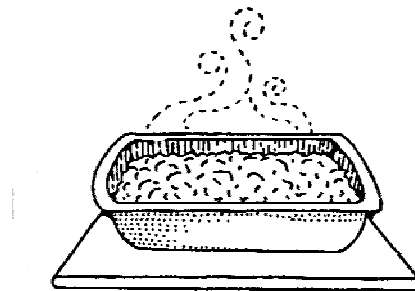

Cooling Liquid Foods -You can use shallow metal pans or you can use the ice and water bath to cool thin soup and sauces. When cooling food with an ice bath, be sure to:

1. Close the drain in a large sink. Place the metal pot or pan of hot food in the sink. The sink drain must be indirectly plumbed.
2. Fill the sink with ice and cold water **up to the level of food in the pot or pan.**
3. Stir the soup or sauce often so that it cools all the way to the center. Ice paddles or cooling wands can be used to speed up the cooling process.
4. Add more ice as ice melts.
5. The food must reach 41°F(5°C).

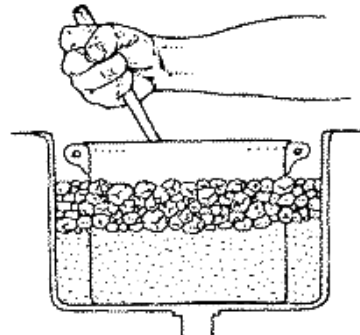

Remember You can choose several ways to cool food. No matter how you cool the food, it must drop from:

2 hours **140 °F (60 °C) to 70 °F (21 °C)** within two hours and then the temperature must drop from

4 hours **70°F(21 °C) to 41°F(5 °C)** within four hours.



Use a food thermometer to check the temperature while it is cooling. If it isn't cooling fast enough you will need to do something else to speed up cooling.

Date Marking **Ready-to-eat** potentially hazardous foods must be date marked with either the preparation date, use-by date, or date the commercial package was opened.

7 days The food can be stored for 7 days when the refrigerator maintains **41°F(5°C)** or colder. Food older than 7 days must be discarded.

1 day Food used within one day is not required to be date marked.

Pests Cockroaches, flies, mice and rats can carry disease and cause damage. Prevention and control of these pests is essential.

Keep the inside and outside areas clean. Outside garbage must be contained in watertight containers with lids remaining closed when not in use. Exclude flies, especially during the warmer months, by screening open doors and windows screened with 1/16th of an inch mesh.

Pests can come into the facility through small holes or gaps under the door to the outside. A mouse can slip through a space of 1/4 inch. Block their entry by eliminating small holes and gaps under and around the door.

If you find pests inside your facility, contact a licensed pest control service.

County contact information for your local health department

Baker 541-523-8211 www.malheurco.org	Lake 541-947-5646
Benton 541-766-6841 www.co.benton.or.us/	Lane 541-682-4051 www.lanecounty.org
Clackamas 503-650-3569 www.co.clackamas.or.us/ph/eh.htm	Lincoln 541-265-4127 www.co.lincoln.or.us/
Clatsop 503-325-8500 www.co.clatsop.or.us/	Linn 541-967-3821 www.co.linn.or.us/Health/Environ_Health
Columbia 503-366-3828 www.columbia-center.org/publichealth	Malheur 541-473-5186 www.malheurco.org
Coos 541-756-2020 www.co.coos.or.us/ph/	Marion 503-588-5346 www.co.marion.or.us/env/envh.htm
Crook 541-447-8155 www.co.crook.or.us/	Morrow 541-278-6394
Curry 541-247-3300 www.co.curry.or.us/publichealth/	Multnomah 503-988-5257 www.mchealthinspect.org/
Deschutes 541-388-6575 www.deschutes.org/go/living-here/	Polk 503-623-9237 www.co.polk.or.us/ComDev/Env_Health/
Douglas 541-464-3820 http://www.co.douglas.or.us/dch/	Sherman 541-506-2600 www.wshd.org
Gilliam 541-506-2600 www.wshd.org	Tillamook 503-842-3918 www.co.tillamook.or.us/gov/health/
Grant 541-575-0429	Umatilla 541--278-6394 www.co.umatilla.or.us/health.htm
Harney 541-573-2271 www.co.harney.or.us/healthdepartment	Union 541-962-8800 www.usgennet.org/usa/or/county/union
Hood River 541-386-1115 www.co.hood-river.or.us	Wasco 541-506-2600 www.wshd.org
Jackson 541-774-8206 www.co.jackson.or.us	Wallowa 541-426-4848
Jefferson 541-475-4456 www.madras.net/newpages/	Washington 503-846-8722 www.co.washington.or.us/deptmts/hhs/
Josephine 541-474-5325 www.co.josephine.or.u	Wheeler 541-475-4456
Klamath 541-883-1122 www.co.klamath.or.us	Yamhill 503-434-7525 www.co.yamhill.or.us/ph

County Contact Information

Inside of Back Cover

Phone numbers and web addresses

**Oregon Department of Human Services
Office of Environmental Public Health
Foodborne Illness Prevention Program**

<http://oregon.gov/DHS/ph/foodsafety>