

POLE TYPE DESIGNATION	SERVICE LOADS				'H1'	'X' VERTS.	'S'
	AXIAL (kips)	SHEAR (KIPS)	MOMEN T (kip-ft)	TORSION (kip-ft)			
WCSM2	2.23	4.14	88.45	38.75	14'-0"	(16) #9	1'-0"
WCSM3	2.85	4.97	110.27	63.78	15'-0"	(16) #9	1'-0"
WCSM4	3.46	5.44	125.28	80.99	15'-6"	(16) #9	0'-10"
WCSM5	4.28	6.04	150.82	121.88	17'-0"	(16) #9	0'-7 1/2"
WCSM6	4.89	6.26	162.83	144.08	17'-0"	(16) #9	0'-6 1/2"
WCSM2L	2.23	4.14	88.45	38.75	14'-0"	(16) #9	1'-0"
WCSM3L	2.85	4.97	110.27	63.78	15'-0"	(16) #9	1'-0"
WCSM4L	3.46	5.44	125.28	80.99	15'-6"	(16) #9	0'-10"
WCSM5L	4.28	6.04	150.82	121.88	17'-0"	(16) #9	0'-7 1/2"
WCSM6L	4.89	6.26	162.83	144.08	17'-0"	(16) #9	0'-6 1/2"

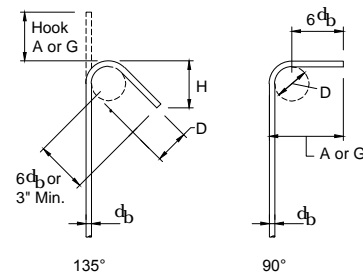
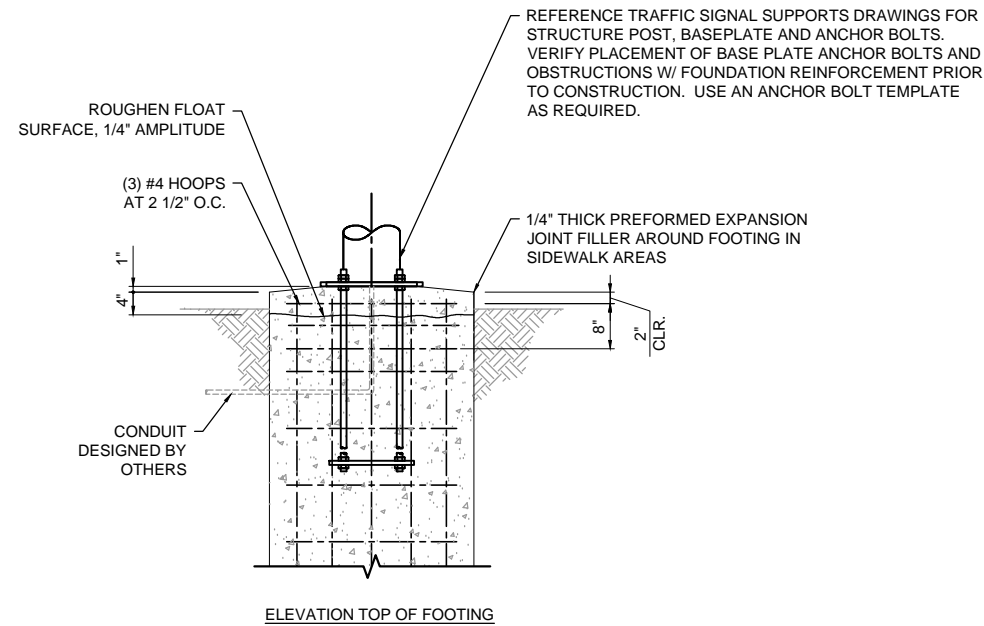
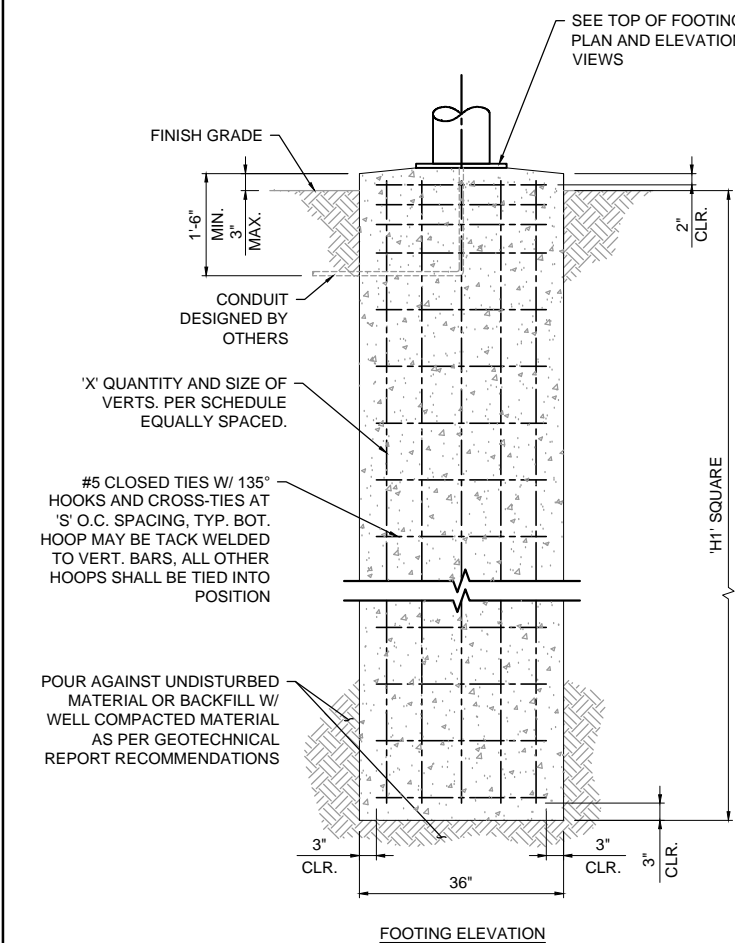
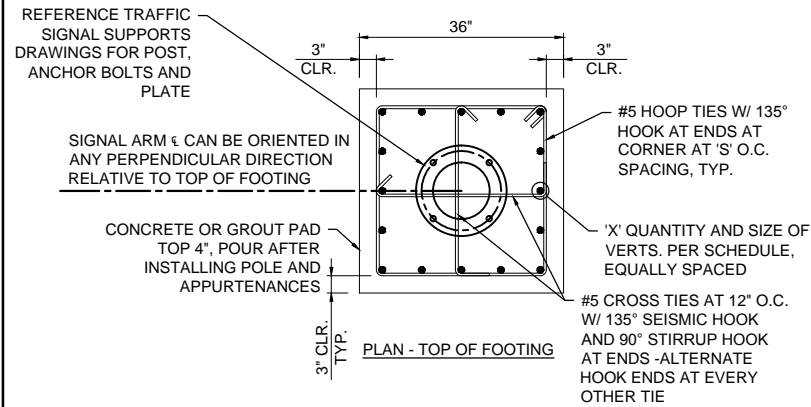

BAR SIZE	90° & 135° SEISMIC HOOK			
	D	90° A or G	135° A or G	H*
#5	2 1/2"	6"	5 1/2"	3 3/4"

\*H DIMENSION IS APPROXIMATE  
 $d_b$  = BAR DIAMETER  
 D = FINISHED INSIDE BEND DIAMETER

**NOTES:**

- MINIMUM CONCRETE COMPRESSIVE STRENGTH = 4000 PSI AT 28 DAYS. A CONCRETE MIX DESIGN SHALL BE FURNISHED BY THE CONTRACTOR FOR REVIEW AND VERIFICATION PRIOR TO CONSTRUCTION. GROUT IN GROUT PADS SHALL BE NON-SHRINK HIGH EARLY STRENGTH GROUT WITH A MINIMUM STRENGTH OF 5000 PSI.
- STEEL TO BE 60 KSI YIELD STRENGTH FOR ALL REINFORCING BARS
- 135 DEGREE AND 180 DEGREE HOOKS ARE TO BE DETAILS AS RECOMMENDED PER THE REQUIREMENTS OF THE CONCRETE REINFORCING STEEL INSTITUTE (CRSI).
- DESIGN LOADS (SERVICE):  
 AXIAL: SEE SCHEDULE  
 SHEAR: SEE SCHEDULE (RESULTANT)  
 MOMENT: SEE SCHEDULE (RESULTANT)  
 TORSION: SEE SCHEDULE  
 (LOADS APPLIED AT TOP OF PILE)
- DESIGN ASSUMPTIONS:  
 - TORSIONAL DESIGN FORCE EQUALS ZERO  
 - SILT (CEMENTED C-PHI SOIL)  
 -  $\phi = 19^\circ$   
 - p-y MODULUS:  $K = 12 \text{ LBS} / \text{IN}^3$   
 -  $\gamma = 60 \text{ LBS} / \text{FT}^3$   
 -  $c = 0$   
 -  $E_{so} = 0$   
 - L-PILE PLUS VERSION 5.0 UTILIZED FOR DESIGN
- ASSUMED ALLOWABLE BEARING CAPACITY IS 1500 PSF.
- SIGNAL POLE FOUNDATION DRILLING IS TO BE MONITORED BY WASHINGTON COUNTY TO VERIFY SUB-SURFACE CONDITIONS ENCOUNTERED MATCH DESIGN ASSUMPTIONS OR IF APPROPRIATE RECOMMEND CHANGES TO DESIGN OR CONSTRUCTION PROCEDURES, BASED ON SPECIFIC CONDITIONS AT DRILLING SITE. NO PERMANENT CASING IS ALLOWED TO REMAIN AROUND SHAFT.

**TRAFFIC SIGNAL SUPPORTS  
 FOUNDATION STANDARD (SQUARE)**

WASHINGTON COUNTY  
 DEPARTMENT OF LAND USE &  
 TRANSPORTATION  
 ENGINEERING SECTION



6921

WASH. CO. #

EFFECTIVE DATE: 9/01/2019

PLOT STAMP: 08/27/19 3:59P ANTHONYD  
 CAD: 6921.DWG